

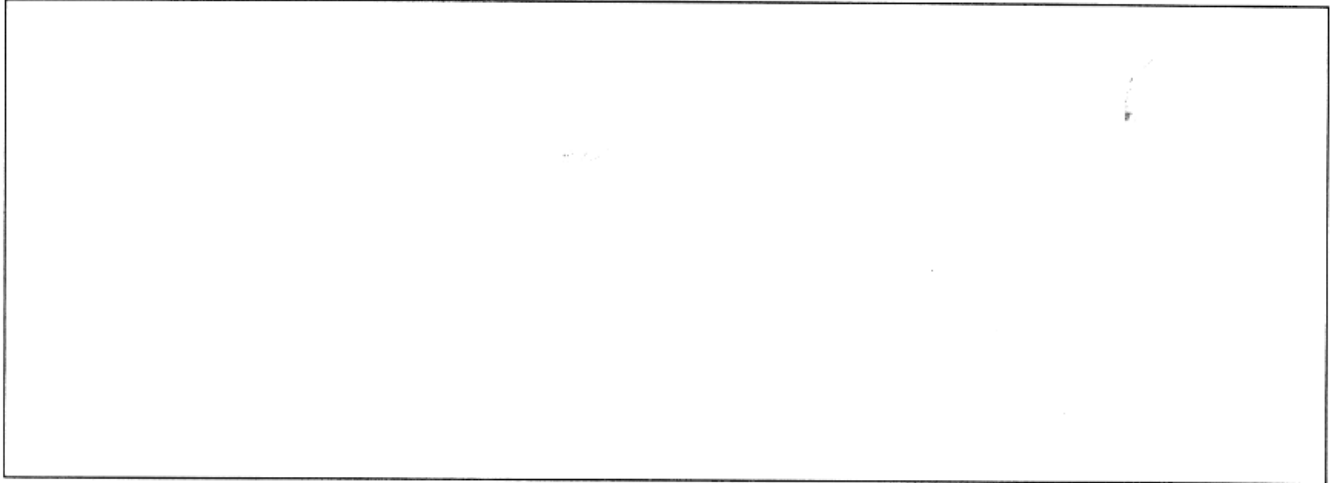

INSTRUCTION MANUAL  
**SHM**  
Sample Holding Module

189-701-00E

December 1974



## 1.1 SCOPE OF MANUAL

This manual contains a description of the analog Sample and Hold Module, instructions for its calibration, adjustment, installation, theory of operation, maintenance instructions, schematic diagrams and assembly drawings.

## 1.2 PURPOSE OF EQUIPMENT

Upon receipt of a sample command pulse, the Sample and Hold Module (SHM) samples an incoming signal and the output reaches a corresponding level within 1 second. When the sample command pulse is removed, the output remains at the sampled level until a new command pulse is received. The SHM is applicable to telemetering systems where data is being transmitted in time-multiplexed pulse-duration or amplitude form. It may also be used in chromatograph systems to store the output representing the quantity of a selected substance. In this application, the sample command may be a momentary contact closure (customer-furnished) across the command-signal input terminals.

Several options modify the sampling cycle of the SHM. Refer to Section 4 for detailed descriptions of these options.

## 1.3 GENERAL DESCRIPTION

An external processing input signal between  $+IN$  and  $-IN$  is applied to a buffer amplifier. The output of this element is sampled by a controlled sampling circuit. If the control signal at the HC terminals is not present, no sampling occurs. When a control signal occurs at HC, the sampling circuit samples the input signal for 100 milliseconds. At the end of that period, the sampling circuit resumes its hold condition, no sampling occurs, and the output of the sampling circuit remains at the level it reached just before the sampling mode was interrupted. The output of the sampling circuit is divided down by a voltage divider. Portions of that signal are picked-off by the SPAN control and amplified to produce the desired output level.

Three major alternative sampling options are available: a track and hold (TR) mode, a peak picker (PP) mode, and an analog output (AO) mode. The TR option allows the state of the control signal to directly control the mode of the sampling circuit. In the peakpicker option, sampling occurs when a peak signal is present on the external input lines. In this option the control input is used as a reset command to force sampling during times other than peak periods. The analog output option allows the external input signal to be buffered out of the SHM at different times during the control cycle. Using dual controls, several variations of controls are possible and are fully described in paragraph 4.2.6.4. Refer to Table 1-1 for a complete list of available SHM electrical options.

Table 1-1. SHM ELECTRICAL OPTIONS

Option	Description	Reference Paragraph
AC	117 VAC or 240 VAC 50 to 60 Hz	4.2.1
CC	External contact closure	4.2.6
SC	Selectable current	4.2.9
TR	Tracking	4.2.6.2
RF	RFI filter terminal assembly	4.2.1
HI	High current or voltage output	4.2.11
PP	Peak power input selection	4.2.6.3
AO	Analog output	4.2.6.4

#### 1.4 PHYSICAL DESCRIPTION

The SHM is available in several different physical configurations. In general, the unit consists of a main circuit board and one small board mounted on the main board. The small board, present in a DC-operated standard unit only, contains the power inverter. The main board contains the remaining circuits. The boards are enclosed in a protective housing, and the entire assembly may be installed in a number of ways. A bracket (supplied when specified in order) may be used to mount the assembly. For hazardous environments, an explosion-proof housing with a base containing up to four threaded hubs for wiring can be supplied. Custom enclosures that are oil-tight and water-tight can also be furnished. Although the printed-circuit board assembly is electrically identical regardless of the physical configuration and mounting method, the external electrical connections may be made to different terminals on the terminal block in the various versions of the unit. Refer to Table 1-2 for a list of mechanical options available. Specific details for making electrical connections are given in Section 2, Installation Information.

Table 1-2. SHM MECHANICAL OPTIONS

Option	Explanation
CP	Conduit plate for use with standard units
EX	Explosion-proof enclosure, Single Unit — Div. 1
GP	General purpose enclosure, Single Unit — NEMA 1
OT	Oil-tight enclosure, Single Unit — NEMA 12
WT	Water-tight enclosure, Single Unit — NEMA 4

**1.5 SPECIFICATIONS**

The specifications of the SHM are given in Table 1-3.

**TABLE 1-3. SHM SPECIFICATIONS****INPUT (PROCESS):**

Current:	1-5 mA, 4-20 mA, 10-50 mA
Voltage:	0-5 VDC, 1-5 VDC Other ranges for current and voltage available

**INPUT (COMMAND):**

Sample:	Customer-furnished momentary external contact closure, not less than 30 milliseconds in duration, to initiate internally gated sample pulse; sample command may also be a h a pulse width not less than 30 milliseconds.
Track:	Customer-furnished external contact closure to maintain unit in track mode; track command may also be a 5 VDC signal (at 1 mA)
Hold (Track Mode):	Open external contacts or reduce command signal to 0 VDC

**INPUT IMPEDANCE:**

Current:	1-5 mA into 200 ohms 4-20 mA into 50 ohms 10-50 mA into 20 ohms
Voltage:	10 megohms minimum

**SPAN AND ZERO:**

	Adjustable with multiturn potentiometer
Span:	At full scale input, adjusts output to $100\% \pm 20\%$ of selected output span
Zero:	At minimum input, adjusts output to $0\% \pm 10\%$ of selected output span

**ISOLATION:**

Voltage output units have input negative side common to output negative side. Current output models have output negative side elevated above input negative side (true current source). Mixed outputs are optionally available. Power input isolation is maintained on both AC and DC powered units

Table 1-3. SHM SPECIFICATIONS (Cont.)

<b>OUTPUT:</b>	Operational amplifier feedback current source. Output limited to 150% of maximum output range value
Current:	1-5 mA into 0- to 6000-ohm load 4-20 mA into 0- to 1500-ohm load 10-50 mA into 0- to 600-ohm load
Voltage:	1-5 VDC standard into 20K Ohms minimum
<b>OUTPUT MODES:</b>	
Sample and Hold:	Output level is made to match the input only after initiation of the command input by a pulse at least 30 milliseconds in duration. One second later, output of unit will automatically become equal to the input present at the time command pulse was received and will remain at this value until the next command pulse is received.
TR Option:	Output level follows (tracks) the input signal continuously while command input is maintained. When command input returns to 0 VDC, output will hold at the level present when the command input (5 VDC) was removed.
<b>HOLDING DECAY:</b>	2% of full scale per hour
<b>FREQUENCY RESPONSE:</b>	0.5 Hz (3-dB point) while tracking the input
<b>CALIBRATED ACCURACY:</b>	$\pm 0.1\%$ of full scale
<b>LOAD RESISTANCE EFFECT:</b>	$\pm 0.01\%$ of span from zero to maximum load resistance (for current output)
<b>OUTPUT RIPPLE:</b>	10 mV P/P at maximum load resistance and maximum span
<b>AMBIENT TEMPERATURE RANGE:</b>	0°F to +150°F (—18°C to +66°C)
<b>AMBIENT TEMPERATURE EFFECT:</b>	$\pm 0.005\%/^{\circ}\text{F}$ over above range; compensation curves for extended ambient ranges available
<b>POWER INPUT:</b>	24 VDC standard, maximum optional 65 VDC $\pm 10\%$ 117 VAC 50/60 Hz or 220 VAC 50/60 Hz optional 5 watts maximum Other supply voltages available Line voltage effect $\pm 0.005\%/1\%$ line change

## 1.6 MODEL NUMBERING SYSTEM

Model numbers describe an instrument's type, functional range, and features. If all accompanying documentation of a unit should be missing, one can still "translate" the Model Number back into a working description of the unit by using the information in this paragraph as a reference.

**Table 1-4. EXAMPLE OF MODEL NUMBERING**

### BASIC EXAMPLE:

SHM, 4-20 mA input, 4-20 mA output, 117 VAC power, tracking mode output

**SHM/4-20MA/4-20MA/ 117AC /TR**

### BASIC INSTRUMENT TYPE:

SHM indicates Sample and Hold Module

### INPUT RANGE:

Numbers: Minimum and maximum nominal input range, generally an industry standard

### OUTPUT RANGE:

Numbers: Minimum and maximum nominal output range, generally an industry standard

### POWER INPUT:

AC: AC power, 117 VAC  $\pm 10\%$  unless stated otherwise, e.g., 240 VAC

DC: DC power, 24 VDC  $\pm 10\%$  (45 VDC  $\pm 10\%$  may be specified as an option)

### OPTIONS:

TR: Indicates Track and Hold option

### INPUT AND OUTPUT ABBREVIATIONS

MA = milliamperes      V = volts

---

**INSTALLATION INFORMATION****2.1 GENERAL INSTALLATION INFORMATION**

Installation, in general, consists of calibration (when required), mechanical mounting, and making the electrical connections to the unit. The necessary procedures are described in paragraph 2.3 and those following that paragraph. Before actually calibrating the unit, however, the reader should first become familiar with the type of controls on the unit and the tools (if any) required for adjustment; these are described in paragraph 2.2.

**2.2 CONTROLS**

Several types of controls are provided on standard Moore Industries products. They have been carefully selected to fulfill the necessary electrical requirements and also provide optimum ease of adjustment by the user. Standard units have multiturn potentiometers that are adjusted with a blade screwdriver.

**CAUTION**

**SCREWDRIVER BLADE MUST NOT BE MORE THAN 0.1 INCH (2.54 mm) WIDE. USE OF A WIDER BLADE MAY PERMANENTLY DAMAGE THE POTENTIOMETER MOUNTING.**

This type of potentiometer usually requires 20 turns of the shaft to move the wiper from one end of its range to the other. It is equipped with a slip clutch at either end of its travel to prevent damage if it is turned beyond the wiper stop. Usually a slight change in feel will be noticed when the clutch is slipping; however, if this change is not observed, one can be certain of reaching either end by turning the shaft 20 turns in the desired direction. Controls are connected so turning the shaft clockwise increases the quantity or makes it more positive, and turning the shaft counterclockwise has the opposite effect.

When present, internal adjustable controls are single-turn potentiometers that require a screwdriver with a blade not more than 0.1 inch (2.54 mm) wide. Since these devices do not have slip clutches, care must be used to avoid overtightening them.

**2.3 CALIBRATION**

Units are calibrated and checked for proper performance at the factory before they are shipped. However, unless calibration was requested to a specific set of input-output values, the unit should be calibrated by the user before the unit is placed in service.

**NOTE**

Adjustments should *not* be made in the field on units that are calibrated to values specified in the purchase order. Units that are calibrated at the factory to customer's specifications have protective caps over the SPAN and ZERO potentiometers; do NOT remove these caps.

One adjustable signal source, a contact closure (switch or relay) or a 5-volt signal source capable of delivering at least 1 mA, and input and output monitoring devices are required for calibration. The monitoring devices (current or voltage) must have an accuracy within  $\pm 0.05\%$  or better.

The calibration procedure for units without the TR option ((*Sample-and-hold* units) is slightly different from that for units with the TR (tracking) option (*track-and-hold* units)). Therefore, two different sets of procedures are provided; use the one that corresponds to the configuration of the unit being calibrated, and ignore the other one.

**INSTALLATION INFORMATION****2.3.1 Calibration Procedure For Units Without TR Option**

To calibrate a unit without the TR option, proceed as follows:

- a. Connect unit and test equipment as shown in Figure 2-1.
- b. Apply power input to the unit.

**NOTE**

Refer to paragraph 1.6 for information on how to use the model number to obtain the specified values of minimum and maximum inputs and outputs.

- c. Lower +HC signal to 0V (*open* the switch —CC option) and adjust the process signal source to the minimum value specified for the unit (1 mA, 4 mA, 10 mA, 1 VDC, or whatever the specified minimum input is for the unit).
- d. Momentarily raise +HC signal to +5 VDC, then lower to 0V (close and then open the switch —CC option).
- e. Allow 1 second delay for the output to reach a steady value. Adjust the ZERO potentiometer to obtain 0% output (1 mA, 4 mA, 10 mA, 1 VDC, or whatever the specified 0% output is for the unit).
- f. Adjust the process signal source to the maximum input specified for the unit (5 mA, 20 mA, 50 mA, 5 VDC, or whatever the specified maximum input is for the unit).
- g. Momentarily raise the signal to +5 VDC, lower to 0V (close and then open the switch, CC option).
- h. Allow 1 second delay for the output to reach a steady value. Adjust the SPAN potentiometer to obtain 100% output.
- i. Momentarily raise +HC signal input to +5 VDC (switch is momentarily closed —CC option) with the specified 0% and 100% process input signals applied.
- j. Adjust the process signal source to 25% of input specified for the unit.
- k. Repeat step g.
- m. Check that unit output reaches 25% of output specified.
- n. Adjust the process signal source to 50% of input specified for the unit.
- o. Repeat step g.
- p. Check that unit output reaches 50% of output specified.
- q. Adjust the process signal source to 75% of input specified for the unit.



## INSTALLATION INFORMATION

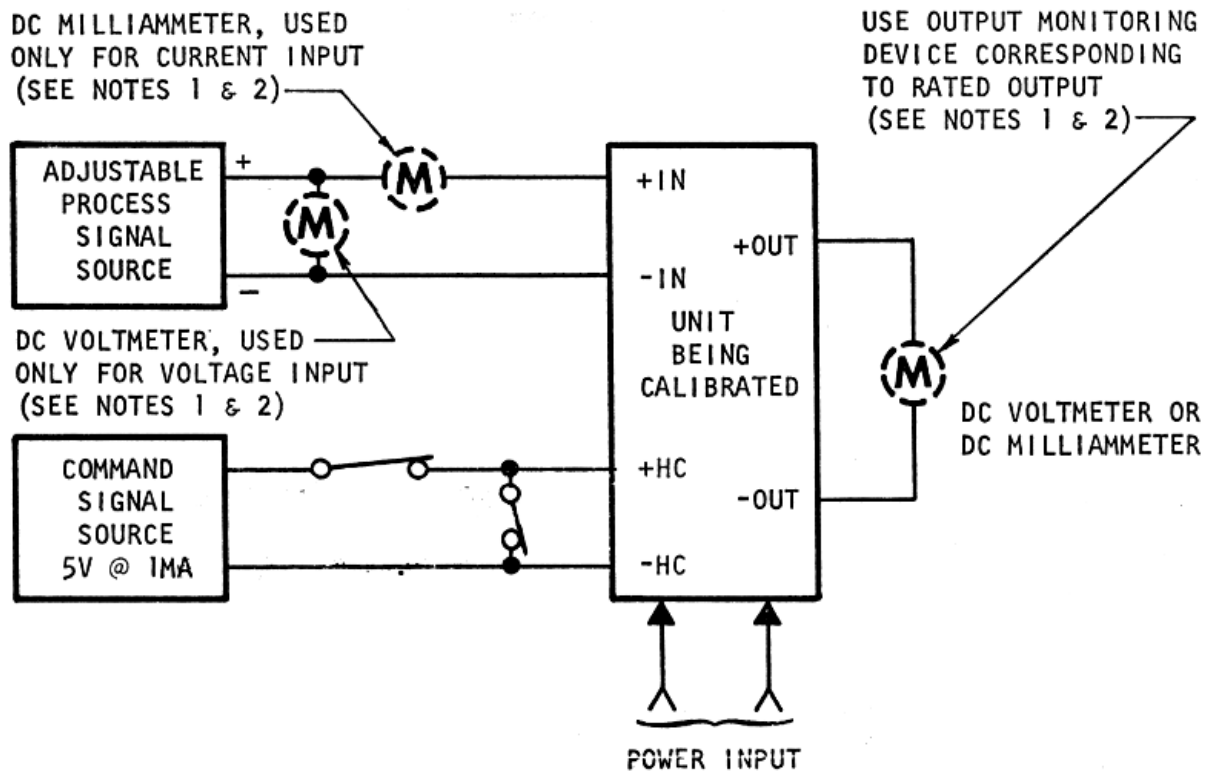

## NOTES:

1. INPUT AND OUTPUT MONITORING DEVICES MUST BE ACCURATE WITHIN 0.05% OR BETTER.

Figure 2-1 Test Equipment Setup For Calibration

- r. Repeat step g.
- s. Check that unit output reaches 75% of output specified.
- t. Remove the input signal sources and turn off the power input to the unit.

### 2.3.2 Calibration Procedure For Unit With TR Option

To calibrate a unit with the TR option, proceed as follows:

- a. Connect unit and test equipment as shown in Figure 2-1.
- b. Apply power input to the unit.

#### NOTE

Refer to paragraph 1.6 for information on how to use the model number to obtain the specified values of minimum and maximum inputs and outputs.

- c. Raise +HC signal to +5 VDC (*close* switch —CC option) and adjust the process signal source to the minimum value specified for the unit (1 mA, 4 mA, 10 mA, 1 VDC, or whatever the specified minimum input is for the unit).
- d. Adjust ZERO potentiometer to obtain 0% output (1 mA, 4 mA, 10 mA, 1 VDC, or whatever the specified 0% output is for the unit).
- e. Lower +HC signal to 0V (open switch —CC option) and observe that the output remains at the value adjusted for in step (d).
- f. Raise +HC signal to +5 VDC (*close* switch —CC option) and adjust the process signal source to the maximum input specified for the unit (5 mA, 20 mA, 50 mA, 5 VDC, or whatever the specified maximum input is for the unit).
- g. Adjust SPAN potentiometer to obtain 100% output (5 mA, 20 mA, 50 mA, 5 VDC, or whatever the specified maximum output is for the unit).
- h. Lower +HC signal to 0V (open switch —CC option) and observe that the output remains at the value adjusted for in step (g).

### 2.3.3 Calibration Procedure For PP Option

To calibrate a unit with the PP Option, proceed as follows:

- a. Repeat steps a, b of paragraph 2.3.2.

### INSTALLATION INFORMATION

- b. Adjust process signal source to the minimum value specified for the unit (1 mA, 4 mA, 10 mA, 1 VDC, or whatever the specified minimum input is for the unit).
- c. Using a millivolt meter, place positive lead on IC1 pin 11 and negative lead on IC1 pin 5.
- d. Raise +HC signal to +5 VDC (or close switch for CC option).
- e. Adjust potentiometer R17 on PC1 for a meter reading of  $7.0 \pm 0.3$  mV.
- f. Adjust ZERO potentiometer to obtain 0% output (1 mA, 4 mA, 10 mA, 1 VDC or whatever specified 0% output).
- g. Lower the +HC input to 0V (or open switch for —CC option).
- h. Adjust process signal source to maximum value specified for unit. Unit output automatically goes to 100% of specified output value.
- i. Adjust SPAN potentiometer to obtain 100% output (5 mA, 20 mA, 50 mA, 5 VDC or whatever the specified maximum output is for the unit).
- j. Raise +HC and repeat steps f through i until correct outputs are obtained.
- k. Adjust process signal source to minimum value specified for unit.
- m. Momentarily raise +HC signal to +5V (or close switch —CC option).
- n. Check that unit output is at 0% of specified output.
- o. Adjust process signal source to 25% of value specified for unit.
- p. Repeat step m.
- q. Check that unit output is at 25% of specified output.
- r. Adjust process signal source to 50% of value specified for unit.
- s. Repeat step m.
- t. Check that unit output is at 50% of value specified for unit.
- u. Adjust process signal source to 75% of value specified for unit.
- v. Repeat step m.
- w. Check that unit output is at 75% of value specified for unit.
- x. Remove input signal sources and power to unit.

### INSTALLATION INFORMATION

#### 2.4 MECHANICAL INSTALLATION

As mentioned in Section 1, the unit may be obtained in various physical configurations and/or case sizes. Figure 2-2 shows the outline dimensions and other installation requirements for the particular configuration supplied. Be sure to observe the applicable special procedures and precautions given with the illustration. Although the units are designed to operate in free air at quite a high ambient temperature, it is advisable if possible to mount the unit on a surface made of material that can serve as a heat sink.

#### 2.5 ELECTRICAL CONNECTIONS

All electrical connections are made to the terminal blocks on the unit. Terminals used for electrical connections are indicated in Figure 2-3. The following paragraphs provide additional information on wiring the unit.

##### 2.5.1 General Wiring Techniques

No special wire or cable is required for signal connections to the unit. To avoid transients and stray pickup, it is recommended that twisted conductors be used where they are run close to other services (such as power wiring). On open units supplied with a snap-off cover, dress all wiring up through the opening in the bottom of the cover. Spade-lug connectors are recommended for all wire terminals. All terminals are supplied with 6-32 screws long enough to easily accept three spade-lug connectors.

##### 2.5.2 Power Connections

Units are designed to be operated from either a DC power source or an AC power source. Refer to paragraph 1.6 for information on how to use the model number to determine the type of power required.

On DC-powered units, the DC terminal is connected to the + (positive) side of the source, and the DCC terminal is connected to the — (negative) side. The DC source should be regulated to within  $\pm 10\%$  of the nominal voltage and should be capable of delivering 5 watts.

On AC-powered units, 117 volts AC  $\pm 10\%$ , 50/60 Hz, 5 VA nominal power is required. The AC terminal should be connected to the ungrounded or "hot" side of the supply, if possible, and the ACC terminal is connected to the common or neutral. The GND terminal is the mechanical case connection.

##### 2.5.3 Connections On Units With SC Option

On units with the SC (selectable current) option, connect the input selectable current resistor to the +IN and —IN terminals. Connect the output selectable current resistor to the terminals marked SC. The current range is marked on the body of each resistor.

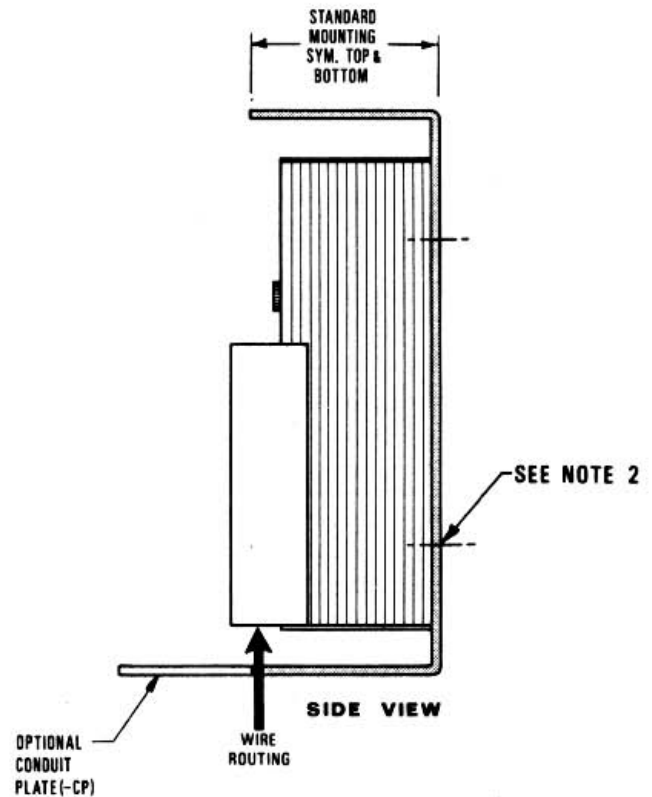
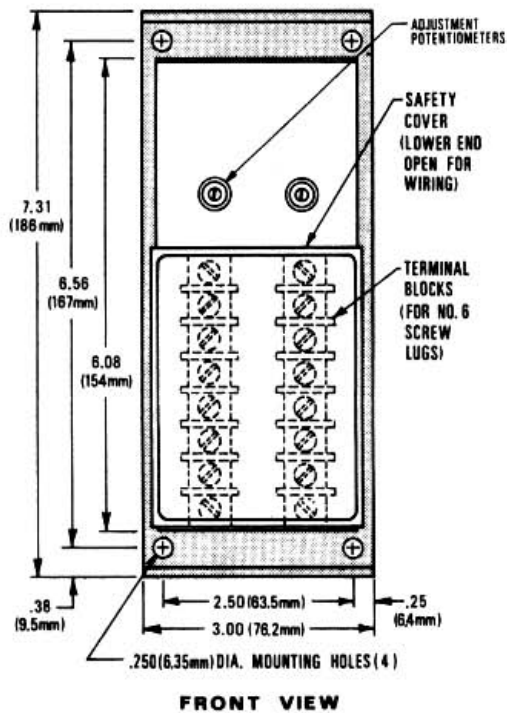
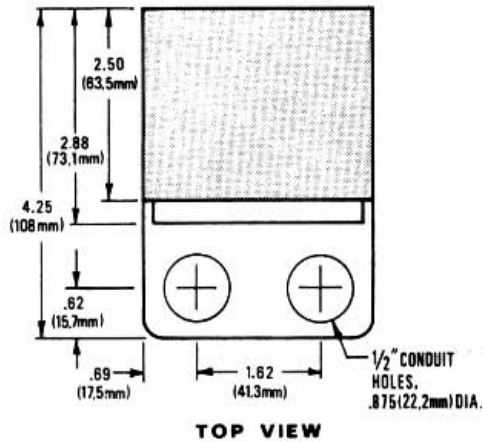

NOTES:

1. Complete Model No. and Serial No. are permanently marked on the identification plate located at the upper end of the terminal blocks.
2. When extra-compact mounting is required for rack or portable installation, the C-shaped mounting bracket may be removed and the two threaded inserts (located 4.00 inches apart) may be used for mounting, using 6-32 NC machine screws.

CAUTION

WHEN THE REAR INSERTS ARE USED FOR MOUNTING, BE SURE THAT THE MOUNTING SCREWS DO NOT PROTRUDE MORE THAN 1/8 INCH INTO THE UNIT.

Figure 2-2. Outline and Installation

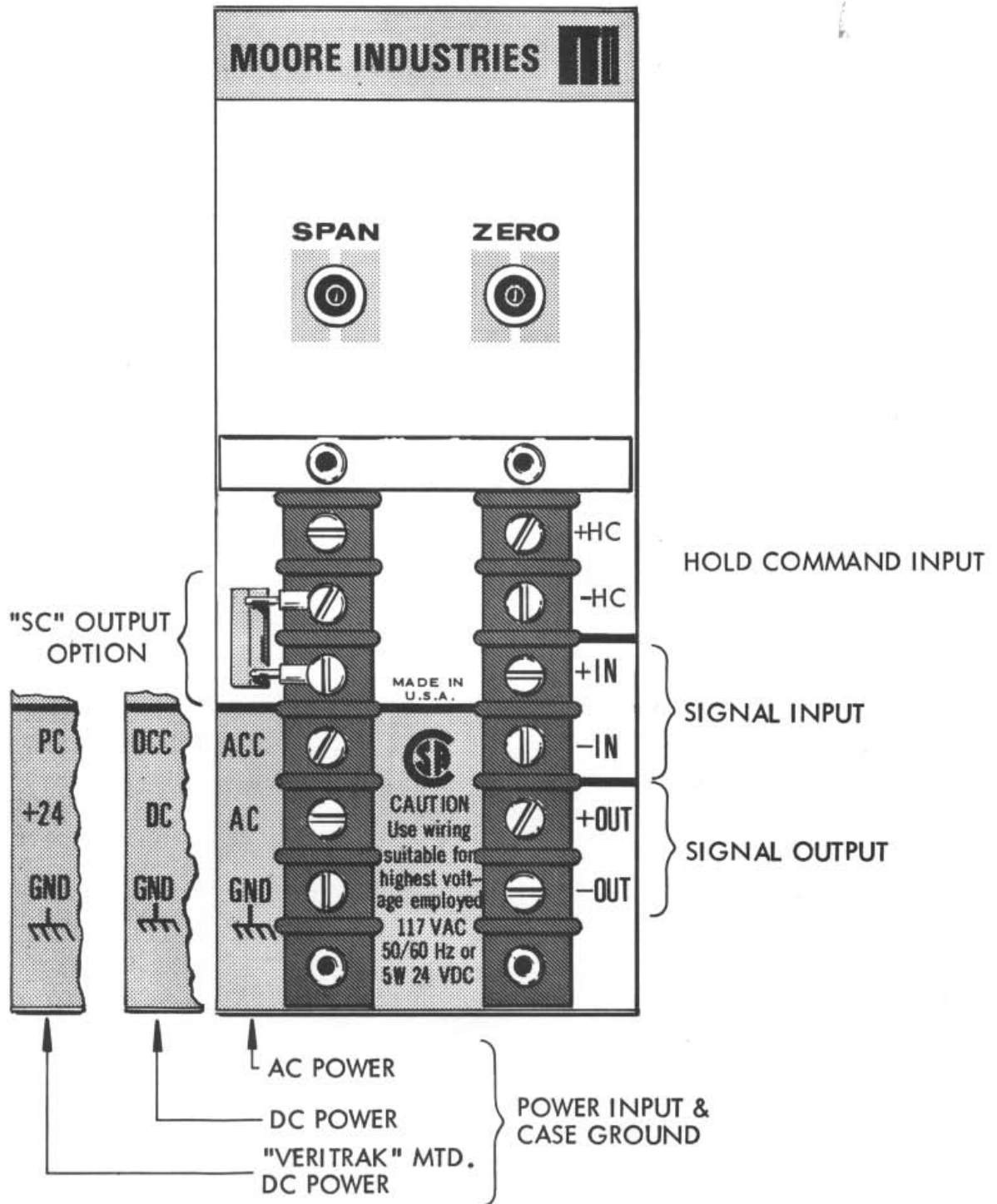

Figure 2-3 Electrical Connections For Standard Unit

17/13

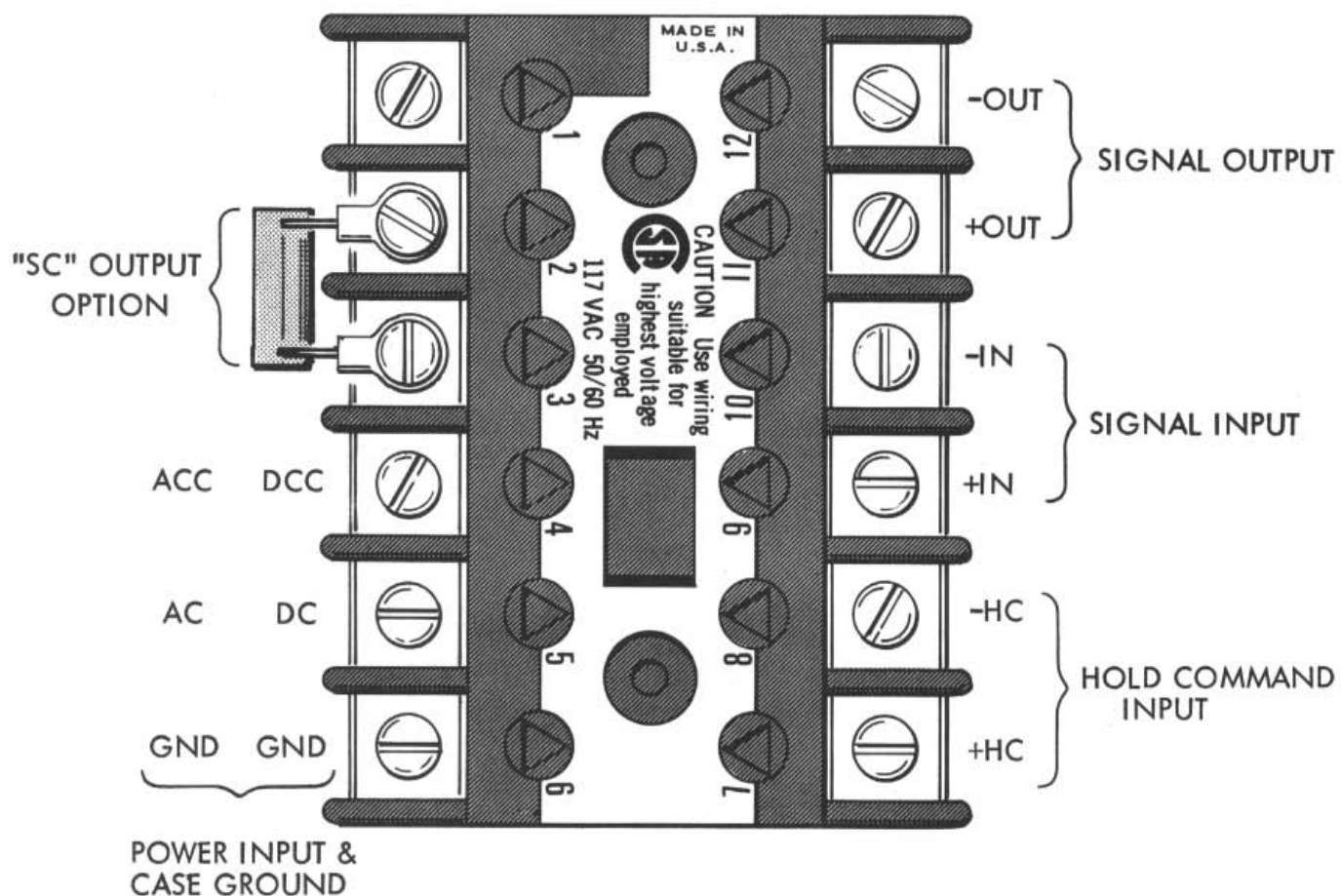

Figure 2-3. Electrical Connections For -EX (Explosion Proof) Housing Mounted Single Unit & -PST Std. Plug-In Units

### **3.1 OPERATING PROCEDURE**

Once calibrated and installed, the unit may be operated unattended. The only controls on the outside of the unit are the SPAN and ZERO potentiometers, which, after initial adjustments, need no further attention. There are no indicators on the unit. Because the circuit uses highly reliable solid state components with no moving parts, the unit should operate virtually maintenance-free for a long period of time. However, if a malfunction should occur, refer to Section 5 for maintenance information.

A unit may become warm during operation, especially where the ambient temperature is rather high. This is perfectly normal and should not be a cause for alarm unless a malfunction is also observed.



---

**THEORY OF OPERATION****4.1 INTRODUCTION**

This section describes the theory of operation of the unit. The description of each circuit is presented in sufficient detail so troubleshooting, if required, can be carried out intelligently and rapidly.

**4.2 CIRCUIT DESCRIPTION**

A schematic diagram and a block diagram (Figure 4-1) of the SHM is included in this manual. Unless otherwise directed, refer to the schematic diagram when reading the following paragraphs.

**4.2.1 Description Of AC Power Supply Circuit (AC and RFI Option)**

The AC power supply circuit consists basically of a power transformer that produces two different AC outputs. Referring to the SHM schematic diagram, VS1 is connected across the primary of power transformer T1 and suppressing transients that may be present on the power line. Each half of the center-tapped secondary of T1 puts out 18 volts, and the other secondary produces 36 volts. The voltage from the center-tapped secondary is applied to CR5 thru CR8, and that from the other secondary is applied to a half-wave rectifier.

**4.2.2 Description Of Power-Inverter Circuit**

In a standard unit, the components of the power inverter are mounted on a printed-circuit board attached to the main board. Descriptions of the power-inverter circuit for the unit are given in the following paragraphs.

**4.2.2.1 *Power-Inverter Circuit For Standard Unit***

Drawing 400-404-00 is the schematic diagram of the power inverter (PCA) used on the standard units. When the unit is ordered for use with DC power, the power inverter is used instead of the AC source (T1) shown on the SHM schematic diagram. The DC applied to the power inverter is converted to a square wave of approximately 3 KHz by Q1, Q2, and the primaries of T1 (PCA schematic diagram), functioning as a DC-to-AC inverter. Filter L1-C1 on PCA prevents the 3-KHz signal from getting back into the external DC source. CR1 provides protection against damage from inadvertent application of DC of incorrect polarity. The square-wave output from center-tapped secondary 8-13 is applied to CR7, CR5, a half wave rectifier, and that from secondary 17-16 is applied to CR202.

**4.2.3 Rectifier And Regulator Circuit For Standard Unit**

Diode bridge rectifiers CR5 through CR8 form a full-wave rectifier that produces both positive and negative DC outputs (with respect to the grounded center tap of the transformer winding that feeds the rectifier). The positive and negative DC outputs from the bridge are filtered by C202 and C203, and regulated to +12 volts and -12 volts by pass transistors Q201 and Q202. Zener diodes CR203 and CR204 are used to clamp the base of the transistors. Voltage from the transformer winding that is not center-tapped is applied to a half-wave rectifier and filter to produce operating voltage of approximately 38 volts for the power amplifier.

**4.2.4 Description Of Input Buffer Circuit**

IC4 and associated components form an input buffer stage. R21 provides the proper termination for a current analog-signal source connected to the +IN and -IN terminals. The signal at the +IN terminal is applied through R31 to pin 3 (the non-inverting input) of IC4. A portion of the output at pin 6 is taken from the junction of IC1 and R14 and fed back through R14 to pin 2 (the inverting input) to establish the gain of this stage.

# SECTION 4

## THEORY OF OPERATION

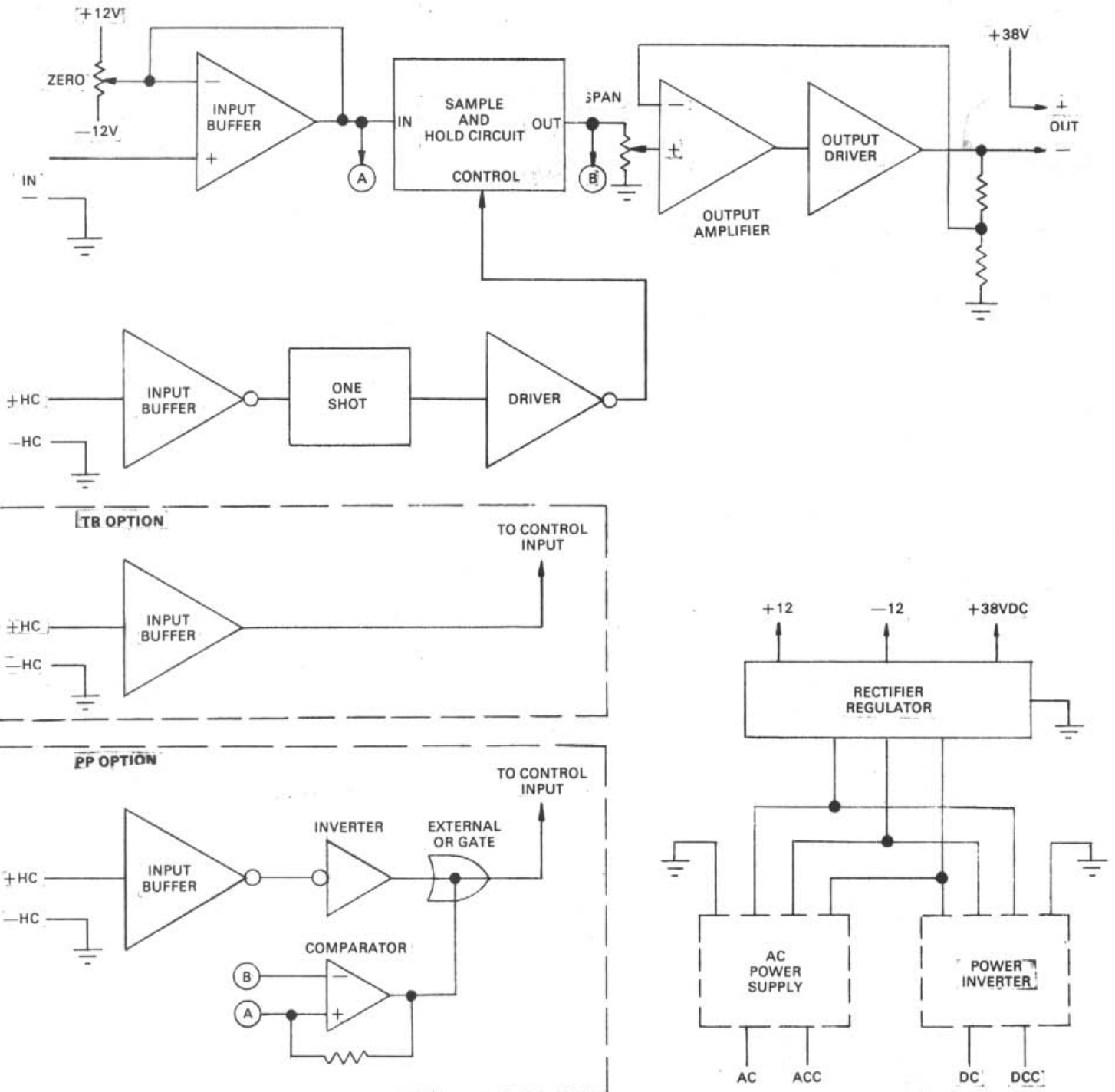

Figure 4-1. SHM With Options Block Diagram

The inverting input also receives the bias Zero signal. This bias is generated by the Zero circuit consisting of voltage divider R9 through R12 ZERO potentiometer and Zener diodes CR1, CR2. The voltage divider, Zener diode network provide a constant signal across the ZERO potentiometer. A shift in the ZERO potentiometer wiper contact can produce either a positive or a negative signal at the inverting input pin 2. This signal is summed with the positive signal at the non-inverting input pin 3. The resultant output of IC4 at pin 6 is an overall gain that is directly affected by the position of the ZERO potentiometer.

#### 4.2.5 Sampling Circuit Description

The sampling circuit consists of sample and hold IC1, offset resistor R17 and the command control circuits. The sample and hold module IC1 samples the signal present at pin 5 and buffers it out on pin 11, in accordance with the state of the control input on pin 6. The control input is normally held at some high state due to the pull-up action of R15. This resistor is referenced internally to a positive signal source derived from the +12V at pin 12. When the control input goes low (near ground), the module ceases to sample the signal at pin 5. During that period, a storage capacitor, C7, holds the input level of the output buffer stage to the state attained just prior to the hold condition. Offset resistor compensates for the offset generated by the peak picker option. Refer to paragraph 4.2.6.3 for a description of R17 action on the sample and hold circuit. During all other modes, R17 is set for an offset between IC1 pin 5 and 11 of 0 volts.

#### 4.2.6 Control Circuit Description

The command gate operates in four major configurations: the standard mode (sample and hold), the tracking mode (the TR option), the peak picker mode (PP option), and the analog output mode (AO option). Figure 4-1 illustrates these modes in block diagram form (except for the AO option). All four inputs may use a positive signal as control or they may use a contact closure. The contact closure (CC option) is effected by an external relay. A +12V source is provided by the SHM (point A in 189-481-00) to provide the necessary excitation power to the +HC command input. The following paragraphs assume the command signal as some positive signal level.

##### 4.2.6.1 *Standard, Sample and Hold Mode*

The standard SHM command circuit illustrated in schematic 189-401-00 consists of a buffer input Q1, a one-shot multivibrator C5, IC2 and a driver Q3. When +HC goes high, Q1 conducts, grounding the input pin 1,2 of IC2. This condition forces IC2-3 high and consequently IC2-11 low, and C5 starts charging, while holding Q3 in cut-off. Since Q3 is off, pin 6 of IC1 is high and sampling of the +IN processing input occurs. When C5 approaches full charge approximately 100 milliseconds, the voltage level on pins 1, 2 of IC2 reaches trigger point of IC2 and IC2-3 goes low forcing IC2-11 high. This event causes Q3 to conduct, effectively grounding pin 6 of IC1 and sampling stops and the hold condition exists. The sample and hold chip IC1 now remains in that state until another command is received at +HC.

##### 4.2.6.2 *TR Option (Tracking Mode)*

The TR option command circuit illustrated in schematic 189-401-00 consists of a buffering circuit Q1 and Q3 that buffers the input command to the control input of IC1 (pin 6). When +HC goes high Q1 conducts, cutting off Q3. This condition provides a high signal on IC1 pin 6 and sampling occurs. When +HC is low Q1 is cut off and Q3 is saturated, grounding pin 6 of IC1 and sampling stops. This circuit then effectively causes the function of the SHM to track the state of the command input.

## THEORY OF OPERATION

4.2.6.3 *PP Option (Peakpicker Mode)*

The peakpicker command circuit consists of a buffer Q1, inverter IC2 and a comparator IC3 and associated components. When no command signal is present at +HC, Q1 is cut off due to the -12 volt reference through R1. With Q1 cut off IC2, pins 1,2 are high, forcing pin 3 low back biasing CR4. This condition disables this section of the control signal and allows the circuit of IC3 to operate.

As IC1 processes the signal input from +IN, the input and output of IC1 are sampled by IC3. The output of IC1 is fed to the inverting input of comparator IC3 while the input of IC1 is provided to the non-inverting input to the comparator. When the processed input signal at IC1 is rising, causing IC1 pin 11 to be lower than pin 5, the output of IC3 at pin 6 goes high. This condition allows IC1 to continue sampling. As long as the input from +IN continues to rise, IC3 pin 6 will be high and sampling will continue.

As soon as the processed input signal at IC1 decreases, IC1 pin 11 is higher than pin 5. Now the inverting input to IC3 sees a larger signal than pin 3, the non-inverting input, and consequently IC3 pin 6 goes low, back biasing CR9. Since R19 is referenced to -12V, pin 6 of IC1 will see a low signal and IC1 stops sampling.

If a command input occurs, +HC is high and Q1 conducts. This forces IC2 pin 3 high, raising IC1 pin 6, and IC1 is forced to sample regardless of the state of IC3. These conditions effectively provide a reset provision for the peak sampling circuit of IC3.

Due to the operating characteristics of IC3, an offset of 7 to 10 millivolts is necessary to obtain the operating specifications described above. Resistor R17 is used to obtain this offset condition and is adjusted at the factory to set IC1-11 at 7 to 10 millivolts higher than IC1-5.

4.2.6.4 *AO Option (Analog Output Mode)*

This option provides mechanization for the control of sampling by two command signals, HC1 and HC2. This option is illustrated on drawing 189-403-00. Buss connections J1 through J10 select various output conditions. If only buss J1, J2, J5, J6, J7, J9 are used, command signals +HC1 and +HC2 operate independently (see Figure 4-2). When +HC1 goes high, Q1 conducts, forcing IC2-3 high, and IC2-11 low, cutting off Q3. This condition provides a high state on IC1 pin 6 (on drawing 189-401-00) and sampling of the +IN signal occurs. As soon as the command is removed, IC1 pin 6 returns low and sampling stops.

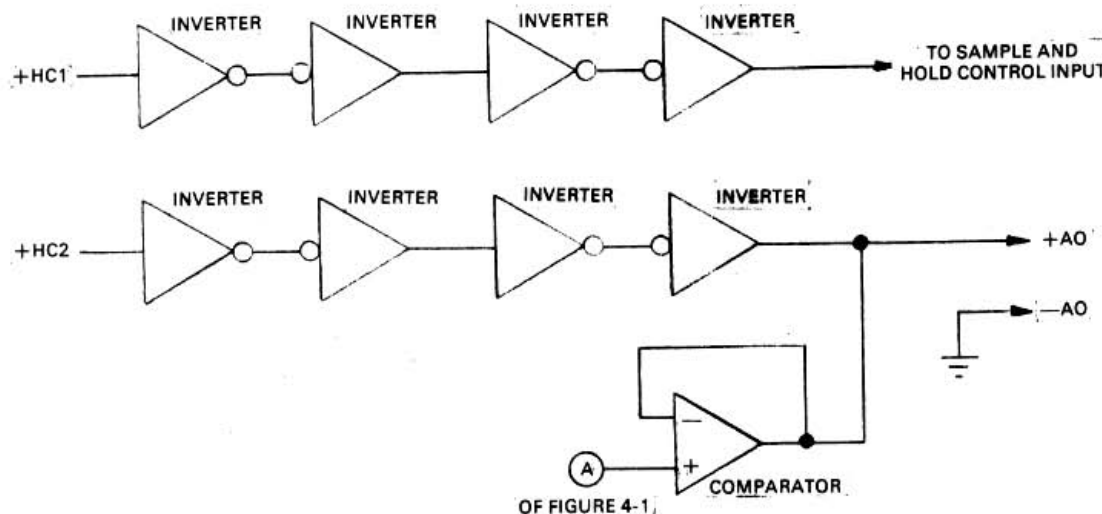

Figure 4-2. Direct Independent Control AO Option

When +HC2 goes high, Q2 conducts, forcing IC2-6 high and IC2-8 low, cutting off Q4. This condition allows unity gain amplifier IC3 to buffer the input processing signal from +IN to terminals +AO. When the command signal is removed, Q2 goes into cutoff due to the -12 volt reference through R8. With Q2 in cutoff, IC2-6 goes low, IC2-8 goes high and Q4 conducts, effectively grounding the output of IC3, and 0V signal is present at the +AO outputs. The +HC2 control just described can be effected by +HC1 and vice-versa if busses J1, J2, J5, J6, J8 and J10 only are used.

If buss connections J1, J3, J4 and J6, J7, J9 only are used, the two command inputs operate in conjunction with each other (see Figure 4-3). If +HC1 is low whenever +HC2 is high, Q1 is cut off while Q2 is conducting. With Q2 conducting, IC2-6 is high. Simultaneously as Q1 is cut off, IC2-3 is low, forcing IC2-11 high. With both high inputs, IC2-8 goes low, feeding back through J3 to IC2-12 thereby holding IC2-11 high. With IC2-11 high, Q3 conducts providing a holding mode condition to IC1 pin 6 of drawing 189-401-00. At the same time with IC2-8 in the low state, Q4 is cut off allowing the +IN signal input to be buffered out to +AO terminals by IC3. These conditions will hold until +HC commands invert polarity.

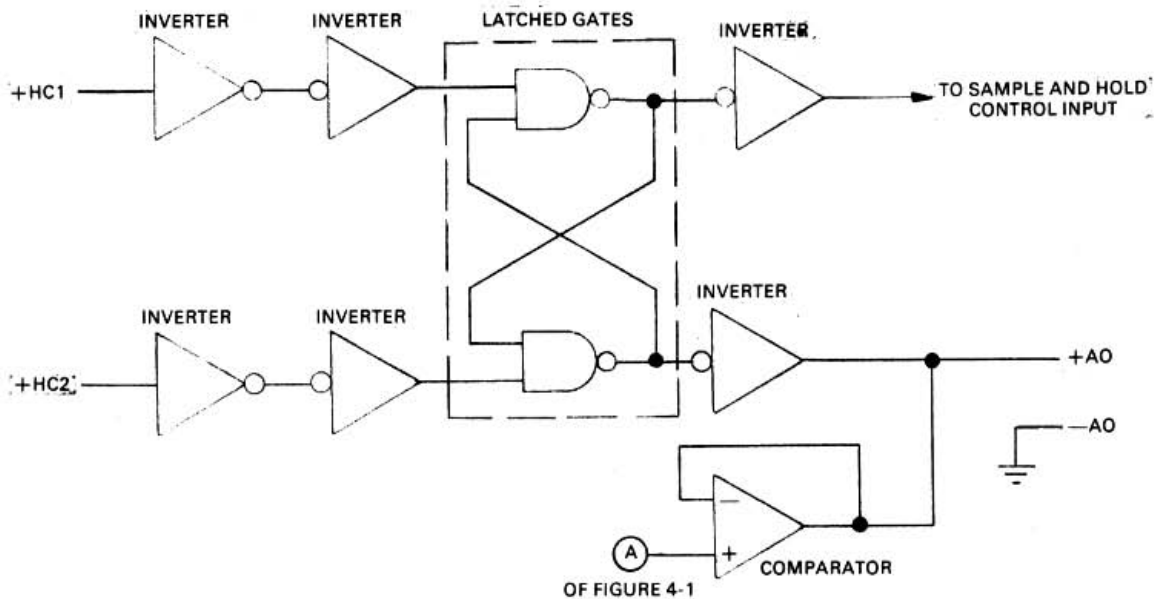

Figure 4-3. Latched Gates AO Option

As +HC1 goes high and +HC2 goes low, Q1 conducts and Q2 is cut off. When Q1 conducts, IC2 pins 1, 2 are low forcing IC2-3 high. Simultaneously as Q2 is cut off, IC2-6 is low, forcing IC2-8 high. This high state propagates to IC2-12 holding IC2-11 low. With IC2-11 low, Q3 is cut off and IC1 of drawing 189-401-00 samples the +IN signal. At the same time, with IC2-8 high, Q4 conducts and grounds the +AO output from IC3.

#### 4.2.7 Output Amplifier Input Circuit Description

Output amplifier IC5 and associated circuits generates the output signal for the SHM. The input of IC5 consists of the output of IC1 divided down by R33, SPAN potentiometer and R34. The SPAN potentiometer wiper selects from 0.2 volts to 1 volt from this voltage divider to produce the output signal.

**4.2.8 Current Output Circuit Description**

Output amplifier IC5 provides drive current to power amplifiers Q5, Q6 and Q7. Transistor Q5, Q7 are connected in a Darlington configuration. Transistor Q6 is connected in parallel with Q7 to generate greater drive to —OUT output terminal. A power source of approximately 38 volts is provided at +OUT. This configuration allows the SHM load between the OUT terminals to be driven directly by the power amplifiers, thereby offering a very low output impedance. Capacitor C3 filters transients from the load circuit.

**4.2.9 Selectable Current (SC) Output Option**

The SC option consists of the additional selectable current resistor R102. All other current output circuits are identical to those described in paragraph 4.2.8. Normally current from the power source flows through the external load through Q6 and R38 to ground. When the SC option is selected, however, R38 is removed and replaced by R102. Load current now flows through R102 and is thereby limited to the value specified by the resistor.

**4.2.9 Voltage Output Circuit Description**

When a voltage output is selected, transistors Q5, Q6 and Q7 are removed and the output of IC5, now a higher gain circuit (gain of 5), provides a high impedance output to the OUT terminals. The load now is between the amplifier output and ground and is in parallel with R38 and R24.

**4.2.10 Millivolts Output Circuit Description**

When millivolt output is selected, the circuit operates as described in paragraph 4.2.8 except that transistor Q6 is removed. The current gain is reduced to millivolt output by the addition of shunt resistor R18. The low value of R18 develops millivolt values across that resistor. Since the resistor is in shunt with the output, the millivolt signal is available across the OUT terminals.

**4.2.11 High Current or Voltage (HI) Output Option**

This option provides higher current or voltage output by adding a driver stage Q7 between output amplifier IC5 and the output terminals. Driver Q7 is powered by a 38 volt source providing the drive necessary for higher current or voltage. R38, now a 1K resistor, provides the low resistance necessary to generate more current in the output stage. Capacitor C8 is used in amplifier IC5 to minimize the offset generated by the high gain of the amplifier.



**MAINTENANCE INFORMATION****5.1 INTRODUCTION**

This section contains information on maintenance of the unit. General troubleshooting procedures are given, using conventional signal-tracing techniques. Precautions and special techniques used to replace components are also described.

**5.2 PERIODIC MAINTENANCE**

It is suggested that the calibration of the unit be checked approximately every 6 months as described in Section 2. No other periodic maintenance is required.

**5.3 CORRECTIVE MAINTENANCE**

The following paragraphs provide information on corrective maintenance of the unit. Corrective maintenance should be carried out *only* by *qualified* personnel who have read and thoroughly understand the description of circuit operation given in Section 4.

**5.3.1 Disassembly**

To troubleshoot the unit, it is first necessary to disassemble it so the circuit board is exposed. The physical configuration of the unit determines the steps to be followed in disassembly, and these steps are described in the following paragraphs. In all cases, disconnect the input signal and turn off the power input before disassembling the unit.

**5.3.1.1 *Disassembly Of Standard Units***

To disassemble a standard unit, remove the unit from its installed position. If the mounting bracket is used, separate it from the unit by removing the two countersunk screws at the rear of the unit. After the unit has been removed from its installed position, disassemble the unit as follows to gain access to the circuit board:

- a. Remove the two front Phillips-head screws at the top of the unit.
- b. Remove the four Phillips-head screws at the bottom of the unit.
- c. Slide the front panel (with the circuit board still attached) down and free of the sides of the case. Points on the circuit board may now be reached for troubleshooting. It is suggested that the case be used as a container for storing the removed hardware.

**5.3.1.2 *Disassembly Of A Plug-In Unit In A Housing***

To disassemble a plug-in unit in an explosion-proof or other type of housing or enclosure (in addition to the case), proceed as follows:

- a. Use a bar wrench to loosen the housing cover from the base, and then unscrew and remove the housing cover to expose the unit.
- b. If required, remove the unit from the socket by rocking the unit slightly while pulling upward until it is free of the socket. The socket and terminal card are keyed to eliminate error when the unit is reinstalled.

---

**MAINTENANCE INFORMATION****5.3.2 Troubleshooting**

The schematic diagrams include flagged numbers (or letters) at various points in the circuit. Table 5-1 gives the voltages and waveforms at these points for specified input-signal conditions. The assembly drawings show the physical locations of the parts on the circuit board. Bear in mind that the circuit board is protected with a moisture-resistant coating. Therefore, it may be necessary to use a needle-point probe and exert a fair amount of pressure to break through the coating when it is desired to observe the signal or voltage at a specific point. When connecting a probe to a component on the circuit board, exercise care to make sure the probe does not short-circuit to an adjacent component. In general, troubleshooting is carried out by tracing the signal with an oscilloscope and referring to the schematic diagrams to determine what component might be causing an observed abnormal indication. If the original symptom was a complete failure of the unit to operate, the most logical components to suspect are those associated with the power supply in the unit (including any voltage regulators). If the unit was producing an incorrect (but not zero) output, check the outputs from the voltage regulator, and, if these are normal, apply a standard input signal and trace the resulting signal through the unit.

**5.3.3 Component Replacement Techniques And General Precautions**

Replace all defective components with identical parts. Refer to the list of materials for a list of replacement parts. A number appears after the description of some parts in this list. The number indicates the number of spares recommended to be kept on hand for that part, per unit, for up to ten units of the same type. For more than ten units, a spares complement of 10% on the indicated parts should be used.

Most parts used in the unit are quite small and are located in a confined area. Therefore, small hand tools are a necessity when servicing the unit. The following is a summary of the general techniques and precautions that should be observed to prevent damage to components in the unit:

- a. Use a transformer-operated low-voltage soldering iron with a grounded tip and rated at not more than 50 watts. A temperature-controlled tip is desirable.
- b. Use extreme care when unsoldering the leads to any component. Do not keep the soldering iron on a point for more than a few seconds at a time. Use a suction-type solder-removing tool (solder sucker) as an aid in unsoldering transistors and integrated circuits. The protective coating on the unit may be removed with trichlorethane or equivalent. Be sure adequate ventilation is provided when using this or any other chemical.

**NOTE**

Unused connections on integrated circuits are left unsoldered to aid in removal. Refer to the assembly drawing for more complete information.

- c. Do not excessively bend or twist the leads of small components; they break easily.
- d. Before removing a component, observe the lead dress. Be sure that the lead dress of the replacement is the same as that of the original.
- e. Remove all flux from soldered joints with trichlorethane or equivalent.





## MAINTENANCE INFORMATION

## NOTE

Units that were calibrated at the factory to customer's specifications have protective caps over the SPAN and ZERO potentiometers. These caps must be removed so the unit can be recalibrated. LIFT, DO NOT TWIST, the caps off, using a screwdriver tip as a prying tool. Snap the caps back in place, WITHOUT TWISTING, when recalibration has been completed.

- f. Test the unit for proper operation and, if necessary, recalibrate by the procedure given in Section 2. If the unit has the peakpicker option, adjust R17 so that IC5 pin 5 is 7 to 10 millivolts lower than IC5 pin 11. Otherwise adjust R17 so that the difference between IC5-5 and IC5-7 is 0V. When the performance of the unit is known to be satisfactory, apply clear acrylic to reseal the unit where required. Refer to Table 5-1 for signal specifications.
- g. Check that all leads are clear of the board edge before reinstalling the board into its case.
- h. When reinstalling the unit onto the mounting bracket, be sure to use the same screws (or screws of the same size) as the ones removed. Longer screws will damage the unit.

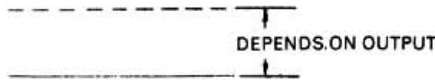
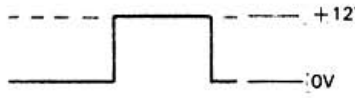
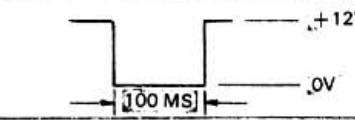
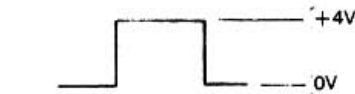
TABLE 5-1. WAVE FORMS AND VOLTAGES

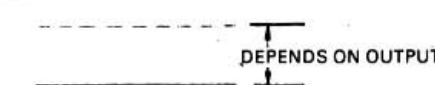
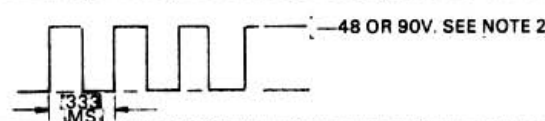
TEST POINT	WAVEFORM AND SIGNAL LEVELS	
1		1.8 TO 9.0V FOR ELEVATED OUTPUT 0 TO 9.0V FOR ZERO OUTPUT
2		+ HC INPUT HIGH + HC INPUT LOW
3		
4		
5		1.8 TO 9.0V FOR ELEVATED OUTPUT 0 TO 9.0V FOR ZERO OUTPUT
6		0.2 TO 1.0V FOR ELEVATED OUTPUT 0 TO 1.0V FOR ZERO BASED OUTPUT
7		

NOTES: 1. Refer to Drawing 400-404-00  
2. 48V when 24 VDC is used  
90V when 45 VDC is used

REV	DATE	BY
1	10/15/78	WJ
2	11/15/78	WJ
3	12/15/78	WJ
4	01/15/79	WJ
5	02/15/79	WJ
6	03/15/79	WJ
7	04/15/79	WJ
8	05/15/79	WJ
9	06/15/79	WJ
10	07/15/79	WJ
11	08/15/79	WJ
12	09/15/79	WJ
13	10/15/79	WJ
14	11/15/79	WJ
15	12/15/79	WJ
16	01/15/80	WJ
17	02/15/80	WJ
18	03/15/80	WJ
19	04/15/80	WJ
20	05/15/80	WJ
21	06/15/80	WJ
22	07/15/80	WJ
23	08/15/80	WJ
24	09/15/80	WJ
25	10/15/80	WJ
26	11/15/80	WJ
27	12/15/80	WJ
28	01/15/81	WJ
29	02/15/81	WJ
30	03/15/81	WJ
31	04/15/81	WJ
32	05/15/81	WJ
33	06/15/81	WJ
34	07/15/81	WJ
35	08/15/81	WJ
36	09/15/81	WJ
37	10/15/81	WJ
38	11/15/81	WJ
39	12/15/81	WJ
40	01/15/82	WJ
41	02/15/82	WJ
42	03/15/82	WJ
43	04/15/82	WJ
44	05/15/82	WJ
45	06/15/82	WJ
46	07/15/82	WJ
47	08/15/82	WJ
48	09/15/82	WJ
49	10/15/82	WJ
50	11/15/82	WJ
51	12/15/82	WJ
52	01/15/83	WJ
53	02/15/83	WJ
54	03/15/83	WJ
55	04/15/83	WJ
56	05/15/83	WJ
57	06/15/83	WJ
58	07/15/83	WJ
59	08/15/83	WJ
60	09/15/83	WJ
61	10/15/83	WJ
62	11/15/83	WJ
63	12/15/83	WJ
64	01/15/84	WJ
65	02/15/84	WJ
66	03/15/84	WJ
67	04/15/84	WJ
68	05/15/84	WJ
69	06/15/84	WJ
70	07/15/84	WJ
71	08/15/84	WJ
72	09/15/84	WJ
73	10/15/84	WJ
74	11/15/84	WJ
75	12/15/84	WJ
76	01/15/85	WJ
77	02/15/85	WJ
78	03/15/85	WJ
79	04/15/85	WJ
80	05/15/85	WJ
81	06/15/85	WJ
82	07/15/85	WJ
83	08/15/85	WJ
84	09/15/85	WJ
85	10/15/85	WJ
86	11/15/85	WJ
87	12/15/85	WJ
88	01/15/86	WJ
89	02/15/86	WJ
90	03/15/86	WJ
91	04/15/86	WJ
92	05/15/86	WJ
93	06/15/86	WJ
94	07/15/86	WJ
95	08/15/86	WJ
96	09/15/86	WJ
97	10/15/86	WJ
98	11/15/86	WJ
99	12/15/86	WJ
100	01/15/87	WJ
101	02/15/87	WJ
102	03/15/87	WJ
103	04/15/87	WJ
104	05/15/87	WJ
105	06/15/87	WJ
106	07/15/87	WJ
107	08/15/87	WJ
108	09/15/87	WJ
109	10/15/87	WJ
110	11/15/87	WJ
111	12/15/87	WJ
112	01/15/88	WJ
113	02/15/88	WJ
114	03/15/88	WJ
115	04/15/88	WJ
116	05/15/88	WJ
117	06/15/88	WJ
118	07/15/88	WJ
119	08/15/88	WJ
120	09/15/88	WJ
121	10/15/88	WJ
122	11/15/88	WJ
123	12/15/88	WJ
124	01/15/89	WJ
125	02/15/89	WJ
126	03/15/89	WJ
127	04/15/89	WJ
128	05/15/89	WJ
129	06/15/89	WJ
130	07/15/89	WJ
131	08/15/89	WJ
132	09/15/89	WJ
133	10/15/89	WJ
134	11/15/89	WJ
135	12/15/89	WJ
136	01/15/90	WJ
137	02/15/90	WJ
138	03/15/90	WJ
139	04/15/90	WJ
140	05/15/90	WJ
141	06/15/90	WJ
142	07/15/90	WJ
143	08/15/90	WJ
144	09/15/90	WJ
145	10/15/90	WJ
146	11/15/90	WJ
147	12/15/90	WJ
148	01/15/91	WJ
149	02/15/91	WJ
150	03/15/91	WJ
151	04/15/91	WJ
152	05/15/91	WJ
153	06/15/91	WJ
154	07/15/91	WJ
155	08/15/91	WJ
156	09/15/91	WJ
157	10/15/91	WJ
158	11/15/91	WJ
159	12/15/91	WJ
160	01/15/92	WJ
161	02/15/92	WJ
162	03/15/92	WJ
163	04/15/92	WJ
164	05/15/92	WJ
165	06/15/92	WJ
166	07/15/92	WJ
167	08/15/92	WJ
168	09/15/92	WJ
169	10/15/92	WJ
170	11/15/92	WJ
171	12/15/92	WJ
172	01/15/93	WJ
173	02/15/93	WJ
174	03/15/93	WJ
175	04/15/93	WJ
176	05/15/93	WJ
177	06/15/93	WJ
178	07/15/93	WJ
179	08/15/93	WJ
180	09/15/93	WJ
181	10/15/93	WJ
182	11/15/93	WJ
183	12/15/93	WJ
184	01/15/94	WJ
185	02/15/94	WJ
186	03/15/94	WJ
187	04/15/94	WJ
188	05/15/94	WJ
189	06/15/94	WJ
190	07/15/94	WJ
191	08/15/94	WJ
192	09/15/94	WJ
193	10/15/94	WJ
194	11/15/94	WJ
195	12/15/94	WJ
196	01/15/95	WJ
197	02/15/95	WJ
198	03/15/95	WJ
199	04/15/95	WJ
200	05/15/95	WJ
201	06/15/95	WJ
202	07/15/95	WJ
203	08/15/95	WJ
204	09/15/95	WJ
205	10/15/95	WJ
206	11/15/95	WJ
207	12/15/95	WJ
208	01/15/96	WJ
209	02/15/96	WJ
210	03/15/96	WJ
211	04/15/96	WJ
212	05/15/96	WJ
213	06/15/96	WJ
214	07/15/96	WJ
215	08/15/96	WJ
216	09/15/96	WJ
217	10/15/96	WJ
218	11/15/96	WJ
219	12/15/96	WJ
220	01/15/97	WJ
221	02/15/97	WJ
222	03/15/97	WJ
223	04/15/97	WJ
224	05/15/97	WJ
225	06/15/97	WJ
226	07/15/97	WJ
227	08/15/97	WJ
228	09/15/97	WJ
229	10/15/97	WJ
230	11/15/97	WJ
231	12/15/97	WJ
232	01/15/98	WJ
233	02/15/98	WJ
234	03/15/98	WJ
235	04/15/98	WJ
236	05/15/98	WJ
237	06/15/98	WJ
238	07/15/98	WJ
239	08/15/98	WJ
240	09/15/98	WJ
241	10/15/98	WJ
242	11/15/98	WJ
243	12/15/98	WJ
244	01/15/99	WJ
245	02/15/99	WJ
246	03/15/99	WJ
247	04/15/99	WJ
248	05/15/99	WJ
249	06/15/99	WJ
250	07/15/99	WJ
251	08/15/99	WJ
252	09/15/99	WJ
253	10/15/99	WJ
254	11/15/99	WJ
255	12/15/99	WJ
256	01/15/00	WJ
257	02/15/00	WJ
258	03/15/00	WJ
259	04/15/00	WJ
260	05/15/00	WJ
261	06/15/00	WJ
262	07/15/00	WJ
263	08/15/00	WJ
264	09/15/00	WJ
265	10/15/00	WJ
266	11/15/00	WJ
267	12/15/00	WJ
268	01/15/01	WJ
269	02/15/01	WJ
270	03/15/01	WJ
271	04/15/01	WJ
272	05/15/01	WJ
273	06/15/01	WJ
274	07/15/01	WJ
275	08/15/01	WJ
276	09/15/01	WJ
277	10/15/01	WJ
278	11/15/01	WJ
279	12/15/01	WJ
280	01/15/02	WJ
281	02/15/02	WJ
282	03/15/02	WJ
283	04/15/02	WJ
284	05/15/02	WJ
285	06/15/02	WJ
286	07/15/02	WJ
287	08/15/02	WJ
288	09/15/02	WJ
289	10/15/02	WJ
290	11/15/02	WJ
291	12/15/02	WJ
292	01/15/03	WJ
293	02/15/03	WJ
294	03/15/03	WJ
295	04/15/03	WJ
296	05/15/03	WJ
297	06/15/03	WJ
298	07/15/03	WJ
299	08/15/03	WJ
300	09/15/03	WJ
301	10/15/03	WJ
302	11/15/03	WJ
303	12/15/03	WJ
304	01/15/04	WJ
305	02/15/04	WJ
306	03/15/04	WJ
307	04/15/04	WJ
308	05/15/04	WJ
309	06/15/04	WJ
310	07/15/04	WJ
311	08/15/04	WJ
312	09/15/04	WJ
313	10/15/04	WJ
314	11/15/04	WJ
315	12/15/04	WJ
316	01/15/05	WJ
317	02/15/05	WJ
318	03/15/05	WJ
319	04/15/05	WJ
320	05/15/05	WJ
321	06/15/05	WJ
322	07/15/05	WJ
323	08/15/05	WJ
324	09/15/05	WJ
325	10/15/05	WJ
326	11/15/05	WJ
327	12/15/05	WJ

REV.	DESCRIPTION	DATE	BY	APPRV
K	ECO # 4533	8/19/86	JVA	JVA

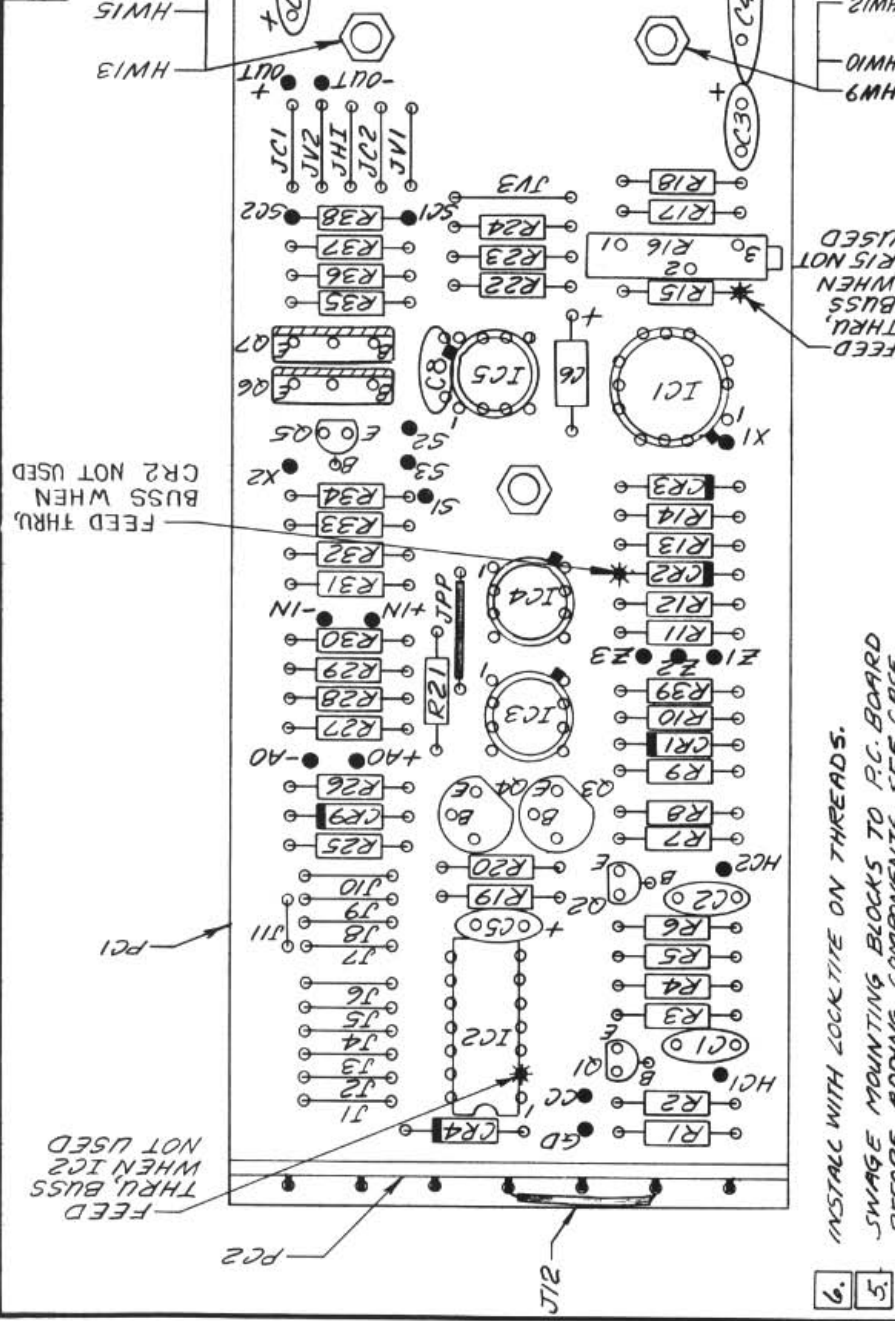

REFERENCE DESIGNATION		MANUFACTURER		PART NAME		LIST OF MATERIALS	
6		MOORE INDUSTRIES INC. VAN NUYS • CALIF.		ASSEMBLY PC1 STANDARD ANALOG SHM		DRAWN R. Kelly 10/14/86	
5		DO NOT SCALE DRAWING		SCALE 2/1"=1"		JOB NO 189	
4		INSTALL WITH LOCKTITE ON THREADS.		SWAGE MOUNTING BLOCKS TO P.C. BOARD BEFORE ADDING COMPONENTS. SEE CASE ASSEMBLY FOR CORRECT PLACEMENT.		CHECK [Signature] 10/23/86	
3		ALL LEADS AND TERMINALS MUST BE SOLDERED TO P.C. BOARD.		JUMPERS ARE 22AWG BUSS, TEFLON SLEEVED AS REQ'D.		PROJ. ENGR. [Signature] 10/23/86	
2		NOTES: UNLESS OTHERWISE SPECIFIED				CUSTR.	
1						DASH ON	

MOORE INDUSTRIES INC. VAN NUYS • CALIF.

ASSEMBLY PC1 STANDARD ANALOG SHM

DO NOT SCALE DRAWING

SCALE 2/1"=1"

JOB NO 189

189-501-00 K

PAGE 1 OF 2

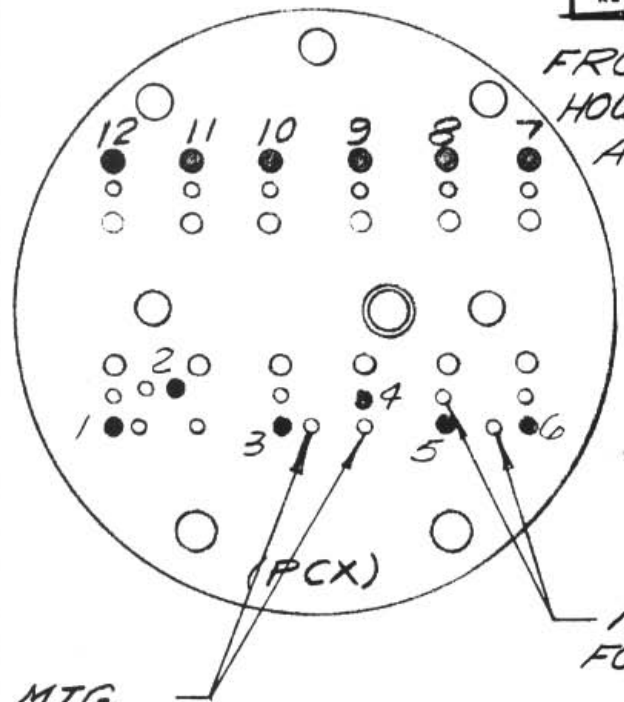

FROM HOUSING ASS'Y

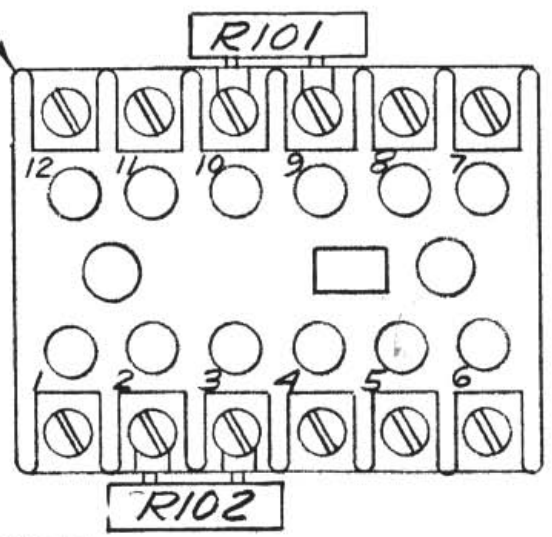

MTG. HOLES FOR C101

MTG HOLES FOR VSI

R101, R102

"SP"

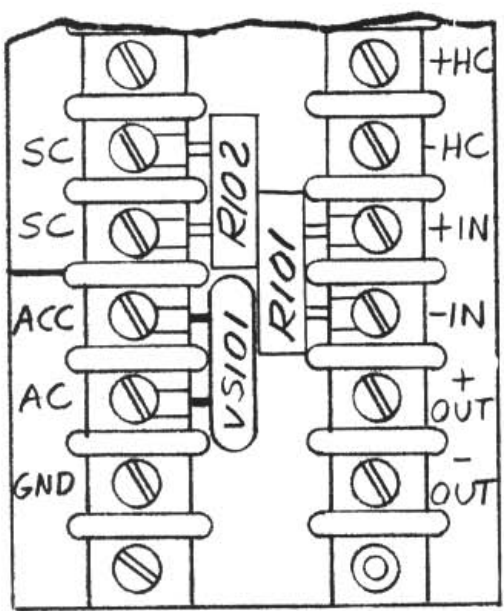

VSI01, R101, R102

"SR & CH"

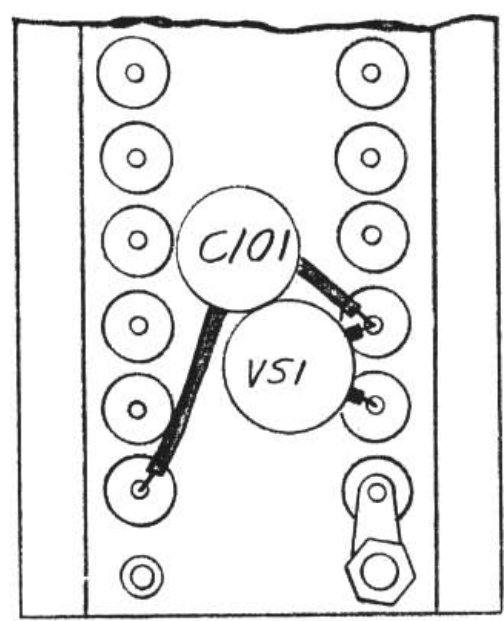

VSI, C101

SLEEVE LEADS

DIMENSIONS ARE IN INCHES UNLESS NOTED OTHERWISE

TOLS. UNLESS NOTED:  
 .X =  $\pm .10$   
 .XX =  $\pm .030$   
 .XXX =  $\pm .010$   
 ANGLES =  $\pm 30^\circ$

DO NOT SCALE DRAWING

SCALE: 1/1

DRAWN	<i>C. FIEDERER</i>	7/17/74
CHECKED	<i>R. Kelley</i>	10/18/74
PROJ. ENGR.	<i>W. [unclear]</i>	10/2/74
CUSTMR.		

**MOORE INDUSTRIES INC.**  
 VAN NUYS ■ CA.

ADDITIONAL PARTS LOC'N,  
 STANDARD ANALOG SHM

DWG. NO. 189-501-00 Pg. 2 of 2

REV. *K*

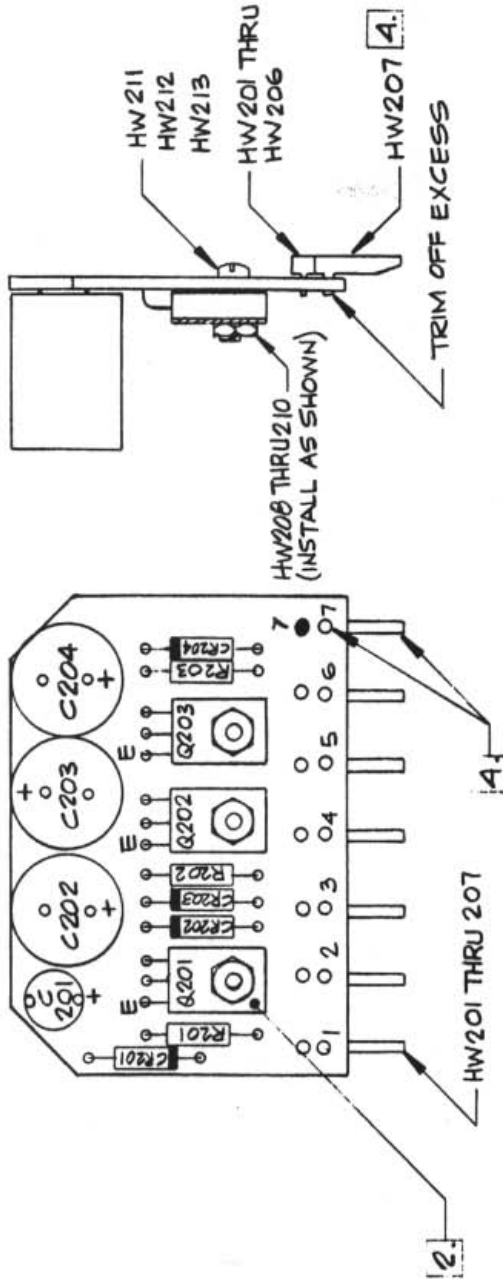

4. CUT HW207 BETWEEN TWO UPPER SOLDER PINS & REMOVE UPPER PORTION PRIOR TO INSERTING & SOLDERING IN BOTTOM HOLE. KEEP TOP HOLE FREE OF SOLDER.
  3. FOR SCHEMATIC SEE DRAWING 189-401-00.
  2. METAL SIDE OF Q201, Q202 & Q203 TO FACE UP; (AWAY FROM BOARD).
  1. ALL LEADS MUST BE SOLDERED TO PADS.
- NOTES: UNLESS OTHERWISE SPECIFIED

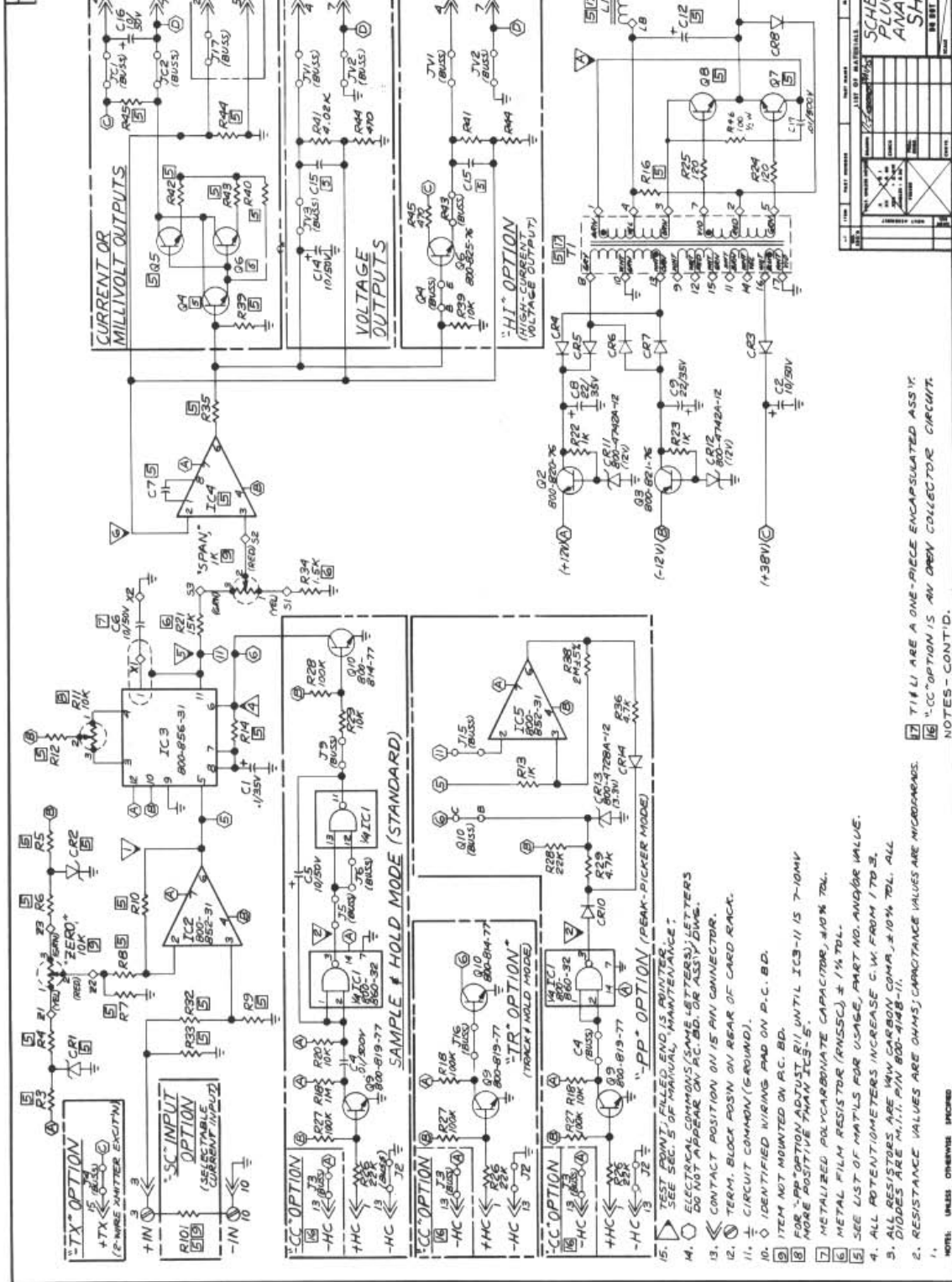

NOTES - CONT'D.

1. TEST POINT FILLED END IS WINTER

2. SEE SEC. 5 OF MANUAL, MAINTENANCE:

3. ELECTRICAL COMMONS (SAME LETTERS) LETTERS DO NOT APPEAR ON P.C.B. OR ASSY. DWG.

4. CONTACT POSITION ON 15 PIN CONNECTOR.

5. TERM. BLOCK POSN ON REAR OF CARD RACK.

6. ± CIRCUIT COMMON (GROUND).

7. IDENTIFIED WIRING PAD ON P.C. B.D.

8. ITEM NOT MOUNTED ON P.C. B.D.

9. FOR "PP" OPTION ADJUST R11 UNTIL IC3-11 IS 7-10MV MORE POSITIVE THAN IC3-5.

10. METALIZED POLYCARBONATE CAPACITOR, 10% TOL.

11. METAL FILM RESISTOR (RMSSC) ± 1% TOL.

12. SEE LIST OF PARTS FOR USAGE, PART NO. AND/OR VALUE.

13. ALL POTENTIOMETERS INCREASE C.W. FROM 170 Ω.

14. DIODES ARE "M.I.I. MIN 800-418-11.

15. RESISTANCE VALUES ARE OHMS; CAPACITANCE VALUES ARE MICROGRAMS.

16. "CC" OPTION IS AN OREY COLLECTOR CIRCUIT.

17. T1 LI ARE A ONE-PIECE ENCAPSULATED ASSY.

SCHEMATIC, ANALOG SHM

189-451-00 C

IBERRE INDUSTRIES INC. THE BERRY CAMP



REV.	DESCRIPTION	DATE	BY	APPROV.
C	ECO 4392	12/24/68	C.S.	[Signature]

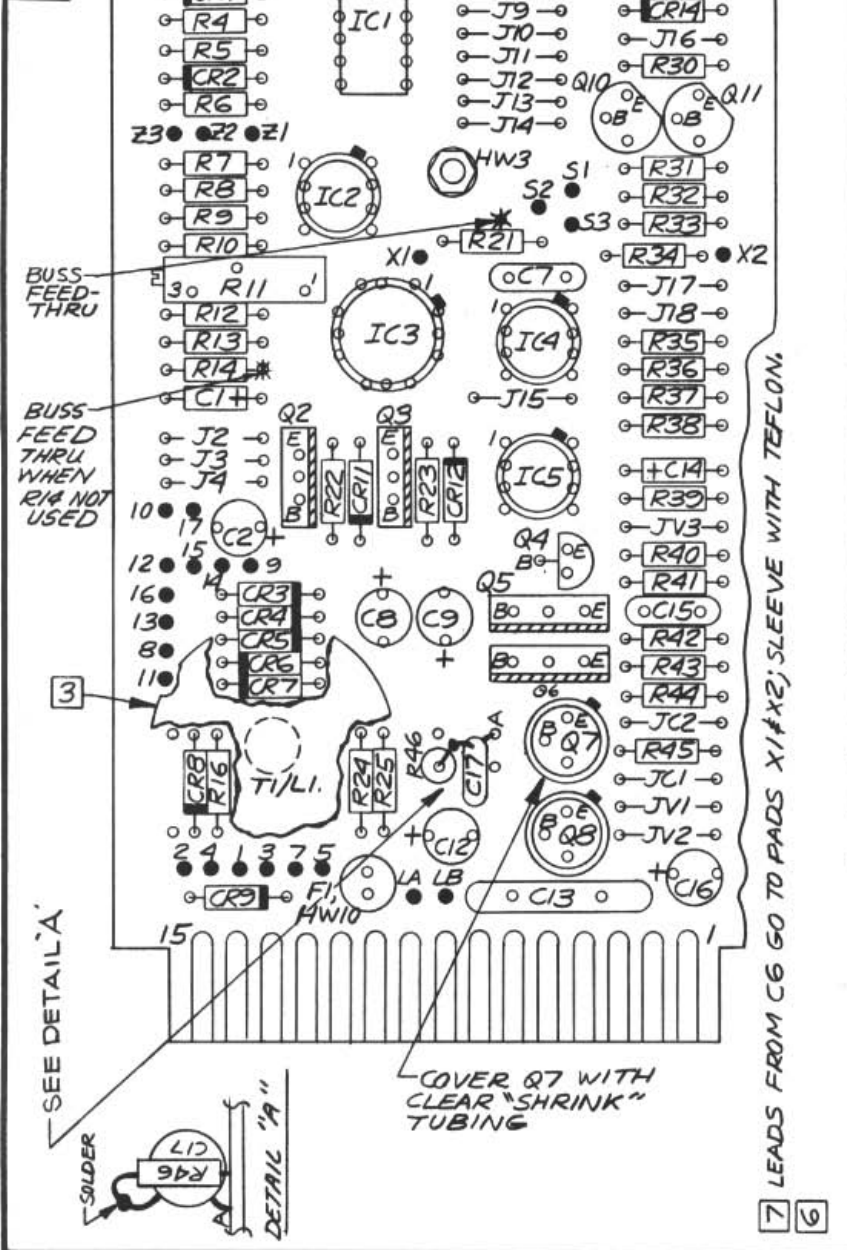

NO. REV'D	ITEM	PART NUMBER	PART NAME	MANUFACTURER	REFERENCE DESIGNATION
-1	7		LEADS FROM C6 GO TO PADS X1#X2; SLEEVE WITH TEFLON.		
	6		IND. METAL SIDE, Q2, Q3, Q5 & Q6. SOLDER LEADS OF R46 & C7 TOGETHER.		
	4		ROR T1/L1 MTG SEE 200-237-00. JUMPERS ARE DRAWN BUSS, TEFLON SLEEVED AS REQ'D.		
	3		ALL LEADS MUST BE SOLDERED TO B6.		

DRAWN		CHECK		PROJ. ENGR.		CUSTR.	
X		XX		XXX		XXXX	
TOLERANCES UNLESS NOTED		ANGLES: ±30°		FINISH		ON	
NEXT ASSEMBLY		NEXT ASSEMBLY		NEXT ASSEMBLY		NEXT ASSEMBLY	
SCALE 2/1		FOR NO 169		DO NOT SCALE DRAWING		SCALE 2/1	

SHM INDUSTRIES INC.  
VAN NUYS • CALIF.

189-551-00C

SHM ASSY, PLUG-IN, ANALOG

DO NOT SCALE DRAWING

SCALE 2/1 FOR NO 169

NOTES: UNLESS OTHERWISE SPECIFIED

## RETURN PROCEDURES

### To return equipment to Moore Industries for repair, follow these four steps:

1. Call Moore Industries and request a Returned Material Authorization (RMA) number.

#### Warranty Repair –

If you are unsure if your unit is still under warranty, we can use the unit's serial number to verify the warranty status for you over the phone. Be sure to include the RMA number on all documentation.

#### Non-Warranty Repair –

If your unit is out of warranty, be prepared to give us a Purchase Order number when you call. In most cases, we will be able to quote you the repair costs at that time. The repair price you are quoted will be a "Not To Exceed" price, which means that the actual repair costs may be less than the quote. Be sure to include the RMA number on all documentation.

2. Provide us with the following documentation:
  - a) A note listing the symptoms that indicate the unit needs repair
  - b) Complete shipping information for return of the equipment after repair
  - c) The name and phone number of the person to contact if questions arise at the factory
3. Use sufficient packing material and carefully pack the equipment in a sturdy shipping container.
4. Ship the equipment to the Moore Industries location nearest you.

The returned equipment will be inspected and tested at the factory. A Moore Industries representative will contact the person designated on your documentation if more information is needed. The repaired equipment, or its replacement, will be returned to you in accordance with the shipping instructions furnished in your documentation.

#### WARRANTY DISCLAIMER

THE COMPANY MAKES NO EXPRESS, IMPLIED OR STATUTORY WARRANTIES (INCLUDING ANY WARRANTY OF MERCHANTABILITY OR OF FITNESS FOR A PARTICULAR PURPOSE) WITH RESPECT TO ANY GOODS OR SERVICES SOLD BY THE COMPANY. THE COMPANY DISCLAIMS ALL WARRANTIES ARISING FROM ANY COURSE OF DEALING OR TRADE USAGE, AND ANY BUYER OF GOODS OR SERVICES FROM THE COMPANY ACKNOWLEDGES THAT THERE ARE NO WARRANTIES IMPLIED BY CUSTOM OR USAGE IN THE TRADE OF THE BUYER AND OF THE COMPANY, AND THAT ANY PRIOR DEALINGS OF THE BUYER WITH THE COMPANY DO NOT IMPLY THAT THE COMPANY WARRANTS THE GOODS OR SERVICES IN ANY WAY.

ANY BUYER OF GOODS OR SERVICES FROM THE COMPANY AGREES WITH THE COMPANY THAT THE SOLE AND EXCLUSIVE REMEDIES FOR BREACH OF ANY WARRANTY CONCERNING THE GOODS OR SERVICES SHALL BE FOR THE COMPANY, AT ITS OPTION, TO REPAIR OR REPLACE THE GOODS OR SERVICES OR REFUND THE PURCHASE PRICE. THE COMPANY SHALL IN NO EVENT BE LIABLE FOR ANY CONSEQUENTIAL OR INCIDENTAL DAMAGES EVEN IF THE COMPANY FAILS IN ANY ATTEMPT TO REMEDY DEFECTS IN THE GOODS OR SERVICES. BUT IN SUCH CASE THE BUYER SHALL BE ENTITLED TO NO MORE THAN A REFUND OF ALL MONIES PAID TO THE COMPANY BY THE BUYER FOR PURCHASE OF THE GOODS OR SERVICES.

ANY CAUSE OF ACTION FOR BREACH OF ANY WARRANTY BY THE COMPANY SHALL BE BARRED UNLESS THE COMPANY RECEIVES FROM THE BUYER A WRITTEN NOTICE OF THE ALLEGED DEFECT OR BREACH WITHIN TEN DAYS FROM THE EARLIEST DATE ON WHICH THE BUYER COULD REASONABLY HAVE DISCOVERED THE ALLEGED DEFECT OR BREACH, AND NO ACTION FOR THE BREACH OF ANY WARRANTY SHALL BE COMMENCED BY THE BUYER ANY LATER THAN TWELVE MONTHS FROM THE EARLIEST DATE ON WHICH THE BUYER COULD REASONABLY HAVE DISCOVERED THE ALLEGED DEFECT OR BREACH.

#### RETURN POLICY

For a period of thirty-six (36) months from the date of shipment, and under normal conditions of use and service, Moore Industries ("The Company") will at its option replace, repair or refund the purchase price for any of its manufactured products found, upon return to the Company (transportation charges prepaid and otherwise in accordance with the return procedures established by The Company), to be defective in material or workmanship. This policy extends to the original Buyer only and not to Buyer's customers or the users of Buyer's products, unless Buyer is an engineering contractor in which case the policy shall extend to Buyer's immediate customer only. This policy shall not apply if the product has been subject to alteration, misuse, accident, neglect or improper application, installation, or operation. THE COMPANY SHALL IN NO EVENT BE LIABLE FOR ANY INCIDENTAL OR CONSEQUENTIAL DAMAGES.



**WORLDWIDE • www.miinet.com**

United States • info@miinet.com Tel: (818) 894-7111 • FAX: (818) 891-2816	Belgium • info@mooreind.be Tel: 03/448.10.18 • FAX: 03/440.17.97	China • sales@mooreind.sh.cn Tel: 86-21-62491499 • FAX: 86-21-62490635
Australia • sales@mooreind.com.au Tel: (02) 8536-7200 • FAX: (02) 9525-7296	The Netherlands • sales@mooreind.nl Tel: (0)344-617971 • FAX: (0)344-615920	United Kingdom • sales@mooreind.com Tel: 01293 514488 • FAX: 01293 536852